

# TECHNICAL DATA

Three Phase Electric Motors - Cast Iron Frame  
 PE30 112M-8  
 1.5 kW / 2 Cv  
 690 RPM

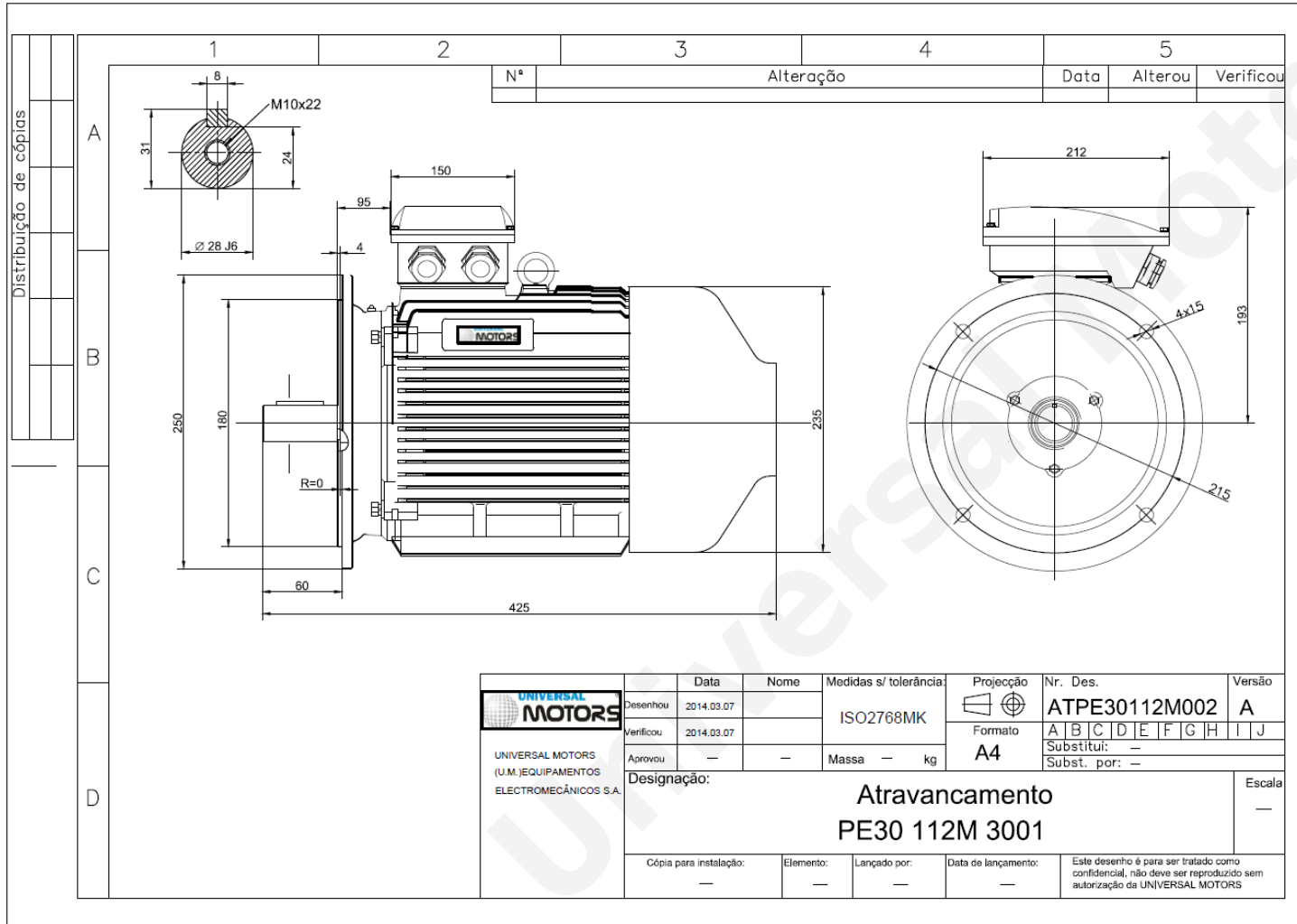

Motor type:	<b>PE30 112M-8</b>
Output:	<b>1.5 kW / 2 Cv</b>
Speed (min <sup>-1</sup> ):	<b>690 RPM</b>
Frequency:	<b>50 Hz</b>
Voltage:	<b>400 V</b>
Current:	<b>3.90 A</b>
Power factor (Cos Ø):	<b>0.70</b>
Poles:	<b>8</b>
Insulation class:	<b>F</b>
Temperature rise Class:	<b>B</b>
Efficiency 50%:	<b>74.6 %</b>
Efficiency 75%:	<b>79.9 %</b>
Efficiency 100%:	<b>79.7 %</b>
Torque:	<b>21 N.m</b>
Tstarting/Tnominal:	<b>1.8</b>
Istarting/Inominal:	<b>5.0</b>
Tmaximum/Tnominal:	<b>2.0</b>
Noise:	<b>61 Db(A)</b>
Weight:	<b>47.5 Kg</b>
Bearing DE:	<b>6306 2Z C3</b>
Bearing NDE:	<b>6306 2Z C3</b>

Regime - S1

Altitude - 1000m

Environment Temperature - 40°C

## CONTACTS:

UNIVERSAL MOTORS Tel: +351 252 299 080  
 Rua de São Brás,745 Fax: +351 252 299 089  
 4480-782 VILA DO CONDE Mail: [geral@universalmotors.pt](mailto:geral@universalmotors.pt)

\* References applied only in the UK